

Origo™

Mig C170 3ph

Mig C200 3ph

Mig C250 3ph

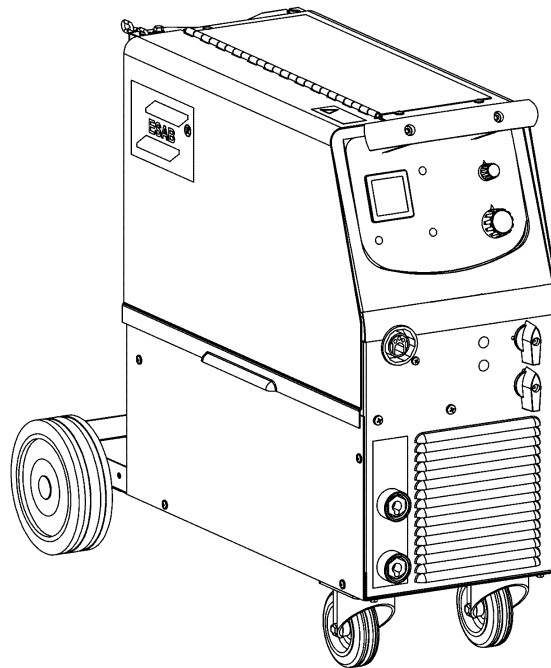

Instruction manual



DECLARATION OF CONFORMITY

According to

The Low Voltage Directive 2006/95/EC, entering into force 16 January 2007

The EMC Directive 2004/108/EC, entering into force 20 July 2007

Type of equipment

Welding power source

Type of designation etc.

Mig C170 3ph, Mig C200 3ph, Mig C250 3ph, from serial number 626 xxx xxxx (2006 w.26)
Mig C170 3ph, Mig C200 3ph, Mig C250 3ph are members of the ESAB product family Origo™

Brand name or trade mark

ESAB

Manufacturer or his authorised representatives established within the EEA:

Name, address, phone, website:

ESAB AB
Box 8004, 402 77 GÖTEBORG, Sweden
Phone: +46 31 509 000, Website: www.esab.com

Factory operating on behalf of the Manufacturer

Name, address, phone, website:

OZAS-ESAB Sp. Z o.o.
ul.A.Struga 10, 45-073 OPOLE, Poland
Phone: +48 77 401 9200, Website: www.esab.com

The following harmonised standard in force within the EEA has been used in the design:

EN 60974-1, Arc welding equipment – Part 1: Welding power sources
EN 60974-10, Arc welding equipment – Part 10: Electromagnetic compatibility (EMC) requirements

Additional information: Restrictive use, Class A equipment, intended for use in locations other than residential.

By signing this document, the undersigned declares as manufacturer, or the manufacturer's authorised representative established within EEA, that the equipment in question complies with the safety requirements stated above.

Date

2012-06-11

Signature

Dariusz Brudkiewicz
Clarification

Position

Managing Director
OZAS-ESAB Sp. z o.o.

1 SAFETY	4
2 INTRODUCTION	6
2.1 Equipment	6
3 TECHNICAL DATA	6
4 INSTALLATION	7
4.1 Location	7
4.2 Assembly of components	8
4.3 Electrical installation	8
4.4 Mains power supply	9
5 OPERATION	9
5.1 Connection and control devices	10
5.2 Welding without gas	11
5.3 Wire feed pressure	11
5.4 Replacing and inserting wire	11
5.5 Overheating protection	12
6 MAINTENANCE	12
6.1 Inspection and cleaning	12
7 FAULT TRACING	13
8 ORDERING OF SPARE PARTS	13
DIAGRAM	14
ORDER NUMBER	18
WEAR PARTS	19
ACCESSORIES	20

1 SAFETY

Users of ESAB equipment have the ultimate responsibility for ensuring that anyone who works on or near the equipment observes all the relevant safety precautions. Safety precautions must meet the requirements that apply to this type of equipment. The following recommendations should be observed in addition to the standard regulations that apply to the workplace.

All work must be carried out by trained personnel well-acquainted with the operation of the equipment. Incorrect operation of the equipment may lead to hazardous situations which can result in injury to the operator and damage to the equipment.

1. Anyone who uses the equipment must be familiar with:
 - its operation
 - location of emergency stops
 - its function
 - relevant safety precautions
 - welding and cutting
2. The operator must ensure that:
 - no unauthorised person is stationed within the working area of the equipment when it is started up.
 - no-one is unprotected when the arc is struck
3. The workplace must:
 - be suitable for the purpose
 - be free from drafts
4. Personal safety equipment
 - Always wear recommended personal safety equipment, such as safety glasses, flame-proof clothing, safety gloves.
 - Do not wear loose-fitting items, such as scarves, bracelets, rings, etc., which could become trapped or cause burns.
5. General precautions
 - Make sure the return cable is connected securely.
 - Work on high voltage equipment **may only be carried out by a qualified electrician.**
 - Appropriate fire extinguishing equipment must be clearly marked and close at hand.
 - Lubrication and maintenance must **not** be carried out on the equipment during operation.

**WARNING**

Do not use the power source for thawing frozen pipes.



WARNING



Arc welding and cutting can be injurious to yourself and others. Take precautions when welding and cutting. Ask for your employer's safety practices which should be based on manufacturers' hazard data.

ELECTRIC SHOCK - Can kill

- Install and earth the unit in accordance with applicable standards.
- Do not touch live electrical parts or electrodes with bare skin, wet gloves or wet clothing.
- Insulate yourself from earth and the workpiece.
- Ensure your working stance is safe.

FUMES AND GASES - Can be dangerous to health

- Keep your head out of the fumes.
- Use ventilation, extraction at the arc, or both, to take fumes and gases away from your breathing zone and the general area.

ARC RAYS - Can injure eyes and burn skin.

- Protect your eyes and body. Use the correct welding screen and filter lens and wear protective clothing.
- Protect bystanders with suitable screens or curtains.

FIRE HAZARD

- Sparks (spatter) can cause fire. Make sure therefore that there are no inflammable materials nearby.

NOISE - Excessive noise can damage hearing

- Protect your ears. Use earmuffs or other hearing protection.
- Warn bystanders of the risk.

MALFUNCTION - Call for expert assistance in the event of malfunction.

Read and understand the instruction manual before installing or operating.

PROTECT YOURSELF AND OTHERS!



CAUTION

Read and understand the instruction manual before installing or operating.

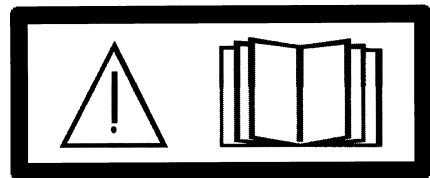

CAUTION

This product is solely intended for arc welding.



CAUTION

Class A equipment is not intended for use in residential locations where the electrical power is provided by the public low-voltage supply system. There may be potential difficulties in ensuring electromagnetic compatibility of class A equipment in those locations, due to conducted as well as radiated disturbances.

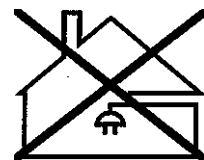

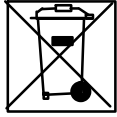

Dispose of electronic equipment at the recycling facility!

In observance of European Directive 2002/96/EC on Waste Electrical and Electronic Equipment and its implementation in accordance with national law, electrical and/or electronic equipment that has reached the end of its life must be disposed of at a recycling facility.

As the person responsible for the equipment, it is your responsibility to obtain information on approved collection stations.

For further information contact the nearest ESAB dealer.

ESAB can provide you with all necessary welding protection and accessories.

2 INTRODUCTION

Mig C170 3ph, Mig C200 3ph and Mig C250 3ph are step controlled power sources of a compact design, intended for welding with solid steel, stainless steel or aluminium wire as well as tubular wire with or without shielding gas. It is possible to weld with homogeneous wire/shielding gas and weld with gasless tubular wire by switching the + and - connections on the switching terminal by the wire feed unit.

ESAB's accessories for the product can be found on page 20.

2.1 Equipment

The power source is supplied with:

- Welding gun
- Return cable with return clamp
- Shelf for gas cylinder
- Instruction manual

3 TECHNICAL DATA

	Mig C170 3ph	Mig C200 3ph	Mig C250 3ph
Voltage	400-415V, 3~ 50/60 Hz	400-415V, 3~ 50/60 Hz	230/400-415V, 3~ 50/60 Hz
Permissible load at 100% duty cycle	100A	120A	150A
60 % duty cycle	130A	150A	190A
35 % duty cycle	170A	200A	250A
Setting range (DC)	30-170A	30-200A	40-280A
Open circuit voltage	15.5-30.6V	16.0-31.8V	15.0-37.0V
Open circuit power	310W	210W	340W
Power factor at max load	0.97	0.97	0.97
Control voltage	42V, 50/60Hz	42V, 50/60Hz	42V, 50/60Hz
Wire feed speed	1.0-17m/min	1.0-17m/min	1.0-17m/min
Burnback time	0.02-0.25s	0.02-0.25s	0.02-0.25s

	Mig C170 3ph	Mig C200 3ph	Mig C250 3ph
Spot welding	0.2-2.5s	0.2-2,5s	0.2-2.5s
Welding gun connection	EURO	EURO	EURO
Wire dimension range	0.6-0.8(Fe, SS) 1.0(Al) 0.8(FCW) 0.8-1.0(CuSi)	0.6-1.0(Fe, SS) 1.0(Al) 0.8-1.0(FCW) 0.8-1.0(CuSi)	0.6-1.2(Fe, SS) 1.0-1.2(Al) 0.8-1.2(FCW) 0.8-1.0(CuSi)
Max diameter / weight of wire bobin	300mm/15kg	300mm/15kg	300mm/15kg
Dimensions lwxhx	860x420x730	860x420x730	860x420x730
Weight	63.5kg	72.5kg	82kg
Operating temperature	-10 ÷ +40°C	-10 ÷ +40°C	-10 ÷ +40°C
Transportation temperature	-20 ÷ +55°C	-20 ÷ +55°C	-20 ÷ +55°C
Enclosure class	IP 23	IP 23	IP 23
Application classification	S	S	S

Duty cycle

The duty cycle refers to the time as a percentage of a ten-minute period that you can weld or cut at a certain load without overloading. The duty cycle is valid for 40° C.

Enclosure class

The **IP** code indicates the enclosure class, i. e. the degree of protection against penetration by solid objects or water. Equipment marked **IP23** is designed for indoor and outdoor use.

Application class

The symbol **S** indicates that the power source is designed for use in areas with increased electrical hazard.

4 INSTALLATION

The installation must be carried out by a professional.

Note!

Connect the power source to the electricity mains with a network impedance of 0.268 (C250 3ph) ohm or lower. If the network impedance is higher, there is a risk of flicker in the illuminators.



CAUTION

This product is intended for industrial use. In a domestic environment this product may cause radio interference. It is the user's responsibility to take adequate precautions.

4.1 Location

Position the welding power source in such way that its cooling air inlets and outlets are not obstructed.

4.2 Assembly of components



WARNING

For packing and shipment of the machine the wheels are detached from the unit. Before use attach the wheels according to instruction.

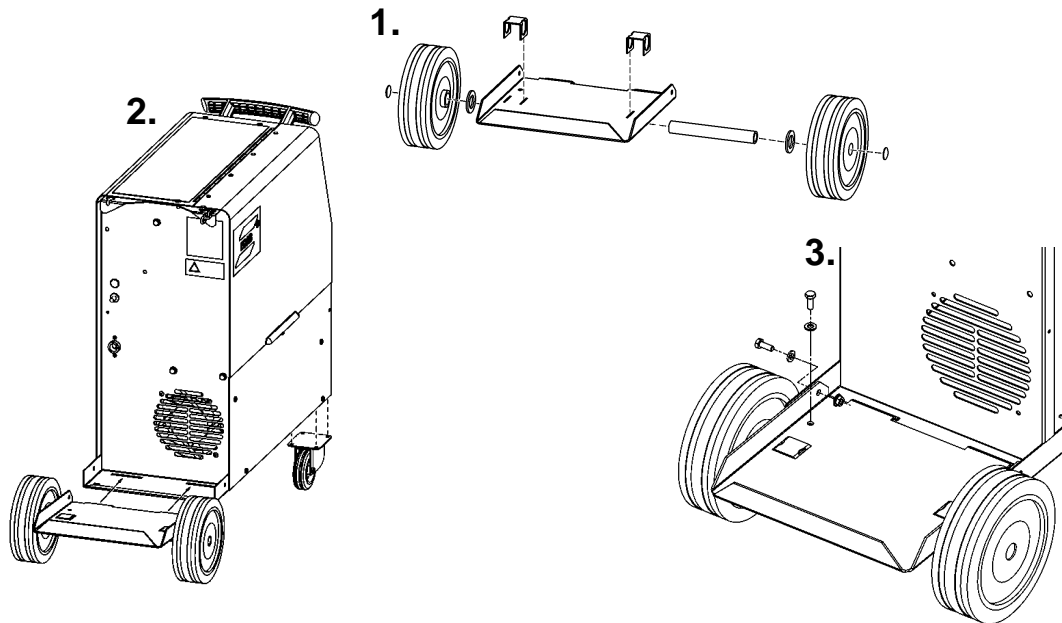

4.3 Electrical installation

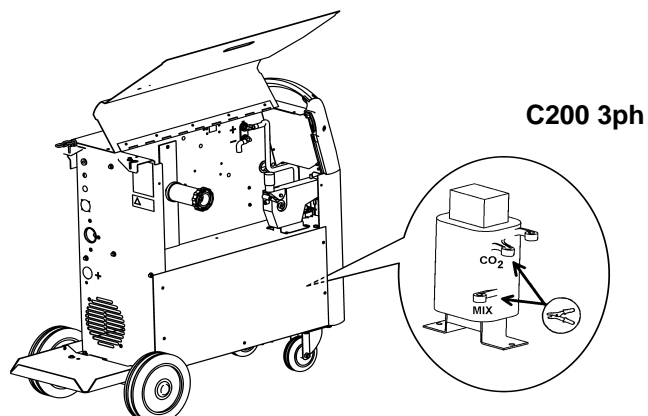
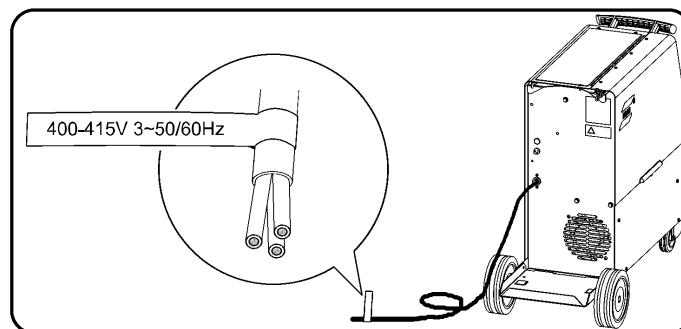

4.4 Mains power supply

Check that the unit is connected to the correct mains power supply voltage, and that it is protected by the correct fuse size. A protective earth connection must be made, in accordance with regulations.

Rating plate with supply connection data

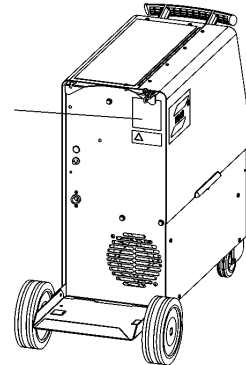

Recommended fuse sizes and minimum cable area

	Mig C170 3ph	Mig C200 3ph	Mig C250 3ph
Voltage V	400-415V, 3~ 50/60 Hz	400-415V, 3~ 50/60 Hz	230 / 400-415V, 3~ 50/60 Hz
Current A at 100% duty cycle	4.0	5.3	12.1/7.0
at 60% duty cycle	6.1	6.8	17.6/10.2
at 35% duty cycle	8.9	10.1	25.3/14.6
Mains Cable area mm ²	4 x 1.5	4 x 1.5	4 x 2.5 / 4 x 1.5
Fuse slow A	10	10	25/16

NB: The mains cable areas and fuse sizes shown above are in accordance with Swedish regulations. They may not be applicable in other countries: make sure that the cable area and fuse sizes comply with the relevant national regulations.

5 OPERATION

General safety regulations for handling the equipment can be found on page 4. Read through before you start using the equipment!



WARNING

Rotating parts can cause injury, take great care.





WARNING

To prevent the reel from sliding off the hub: Lock the reel in place by turning the red knob as shown on the warning label attached next to the hub.

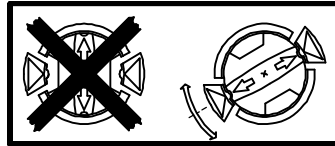



WARNING

Secure the equipment - particularly if the ground is uneven or sloping.

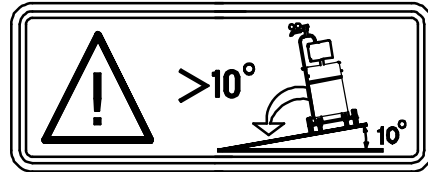

5.1 Connection and control devices

- | | |
|---|---|
| <ul style="list-style-type: none"> 1 Mains supply switch 2 Indicator lamp, power ON/OFF 3 Orange indicator lamp, overheating 4 Welding voltage switch 5 EURO - connector for welding gun 6 Connection for return cable (-), high inductance | <ul style="list-style-type: none"> 7 Connection for return cable (-), low inductance 8 Knob for spot welding - ON/OFF and time setting 9 Knob for wire speed setting 10 Digital instrument - V/A (option, see page 20) 11 Return cable with return clamp * Knob for burn-back time setting (located on control board) |
|---|---|

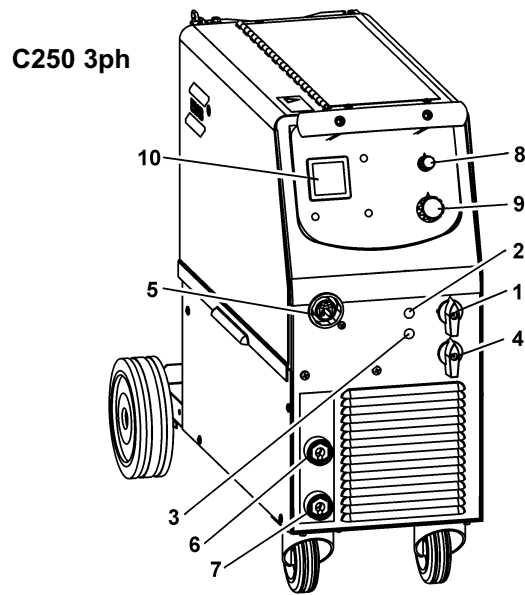
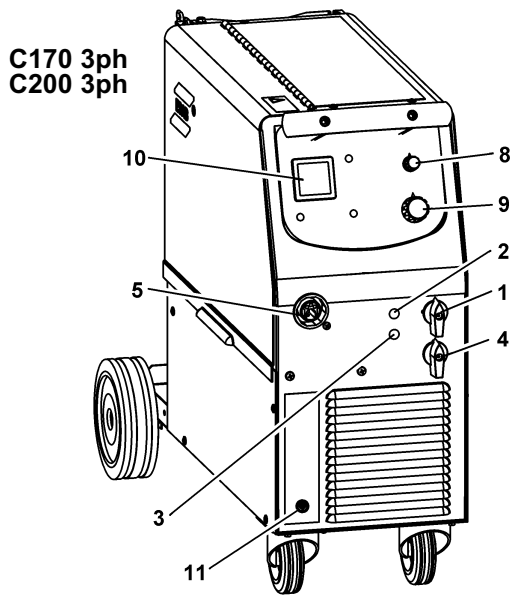

5.2 Welding without gas

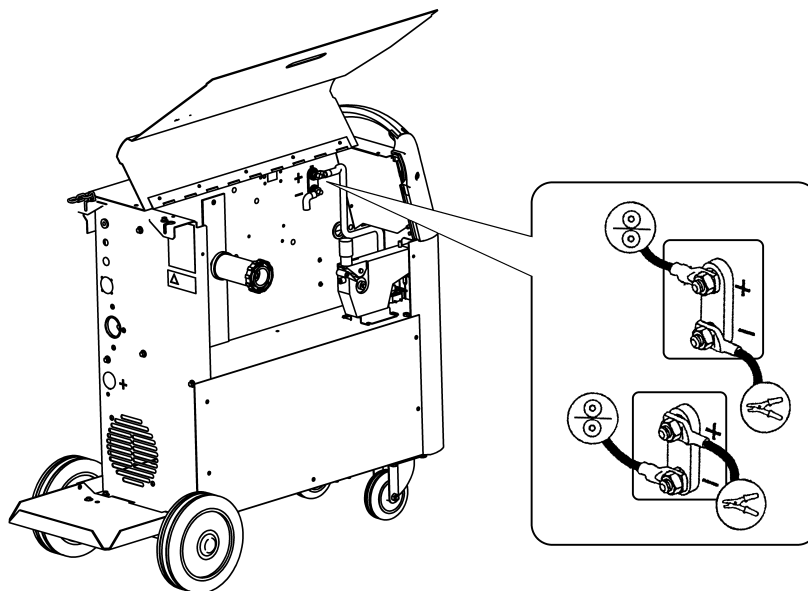

5.3 Wire feed pressure

Start by making sure that the wire moves smoothly through the wire guide. Then set the pressure of the wire feeder's pressure rollers. It is important that the pressure is not too great.

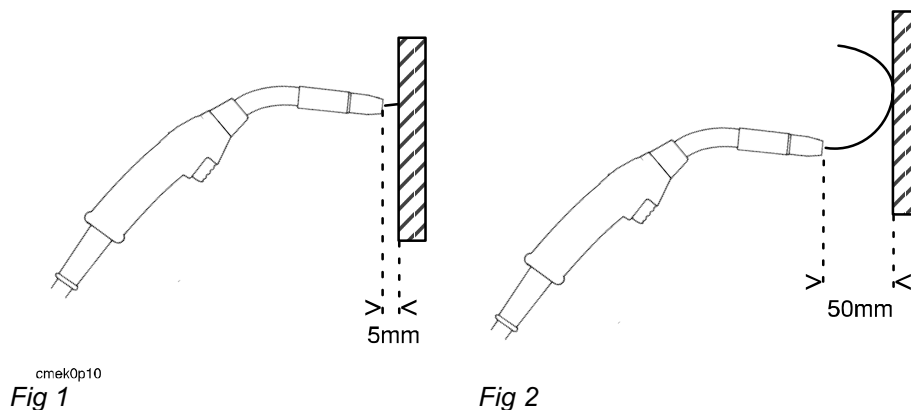

To check that the feed pressure is set correctly, you can feed out the wire against an insulated object, e.g. a piece of wood.

When you hold the gun approx. 5 mm from the piece of wood (fig. 1) the feed rollers should slip.

If you hold the gun approx. 50 mm from the piece of wood, the wire should be fed out and bend (fig. 2).

5.4 Replacing and inserting wire

- Open the side panel.
- Disconnect the pressure sensor by folding it backwards, the pressure rollers slide up.

- Straighten the new wire for 10-20 cm. File away burrs and sharp edges from the end of the wire before inserting it into the wire feed unit.
- Make sure that the wire goes properly into the feed roller track and into the outlet nozzle and the wire guide.
- Secure the pressure sensor.
- Close the side panel.

5.5 Overheating protection

When the machine is switched on with the mains switch [1], indicator lamp [2] is on and lamp [3] off - the machine is ready to operate. If the internal temperature becomes too high, the welding is interrupted and disabled. This state is indicated by lighting of the orange indicator lamp [3] on the front of the machine. It resets automatically when the temperature has fallen.

6 MAINTENANCE

Regular maintenance is important for safe, reliable operation.



CAUTION

All guarantee undertakings from the supplier cease to apply if the customer attempts any work to rectify any faults in the product during the guarantee period.

6.1 Inspection and cleaning

Check regularly that the power source is free from dirt.

The power source should be regularly blown clean using dry compressed air at reduced pressure. It should be cleaned more frequently in dirty environments. Otherwise the air inlet/outlet may become blocked and cause overheating.

Welding gun

- The welding gun's wear parts should be cleaned and replaced at regular intervals in order to achieve trouble-free wire feed. Blow the wire guide clean regularly and clean the contact tip.

The brake hub

The hub is adjusted when delivered, if readjustment is required, follow the instructions below. Adjust the brake hub so that wire is slightly slack when wire feed stops.

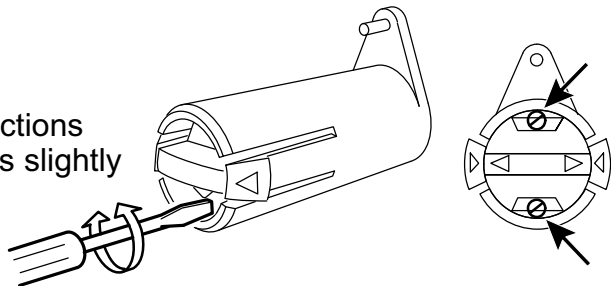

- **Adjusting the braking torque:**

- Turn the red handle to the locked position.
- Insert a screwdriver into the springs in the hub.

Turn the springs clockwise to reduce the braking torque

Turn the springs counter-clockwise to increase the braking torque. **NB:** Turn both springs the same amount.

7 FAULT TRACING

Try these recommended checks and inspections before sending for an authorised service technician.

Type of fault	Actions
No arc	<ul style="list-style-type: none"> • Check that the mains power supply switch is turned on. • Check that the welding current supply and return cables are correctly connected. • Check that correct current value is set.
Welding current is interrupted during welding	<ul style="list-style-type: none"> • Check whether the thermal overload trip has operated (indicated by the orange lamp on the front). • Check the main power supply fuses.
Thermal overload trips operate frequently	<ul style="list-style-type: none"> • Check to see whether the air inlets/outlets are clogged. • Make sure that you are not exceeding the rated data for the power source (i.e. that the unit is not being overloaded).
Poor welding performance	<ul style="list-style-type: none"> • Check that the welding current supply and return cables are correctly connected. • Check that the correct current value is set. • Check that the correct welding wires are being used. • Check the main power supply fuses. • Check the wire feed unit - if proper rolls are applied and properly set the pressure of the wire feeder's pressure rollers

8 ORDERING OF SPARE PARTS

Repair and electrical work should be performed by an authorised ESAB service technician. Use only ESAB original spare and wear parts.

Mig C170 3ph, Mig C200 3ph, Mig C250 3ph is designed and tested in accordance with the international and European standards **IEC-/ EN 60974-1, IEC-/ EN 60974-10**. It is the obligation of the service unit which has carried out the service or repair work to make sure that the product still conforms to the said standard.

Spare parts may be ordered through your nearest ESAB dealer, see the last page of this publication.

Diagram

Mig C170 3ph, 400-415V

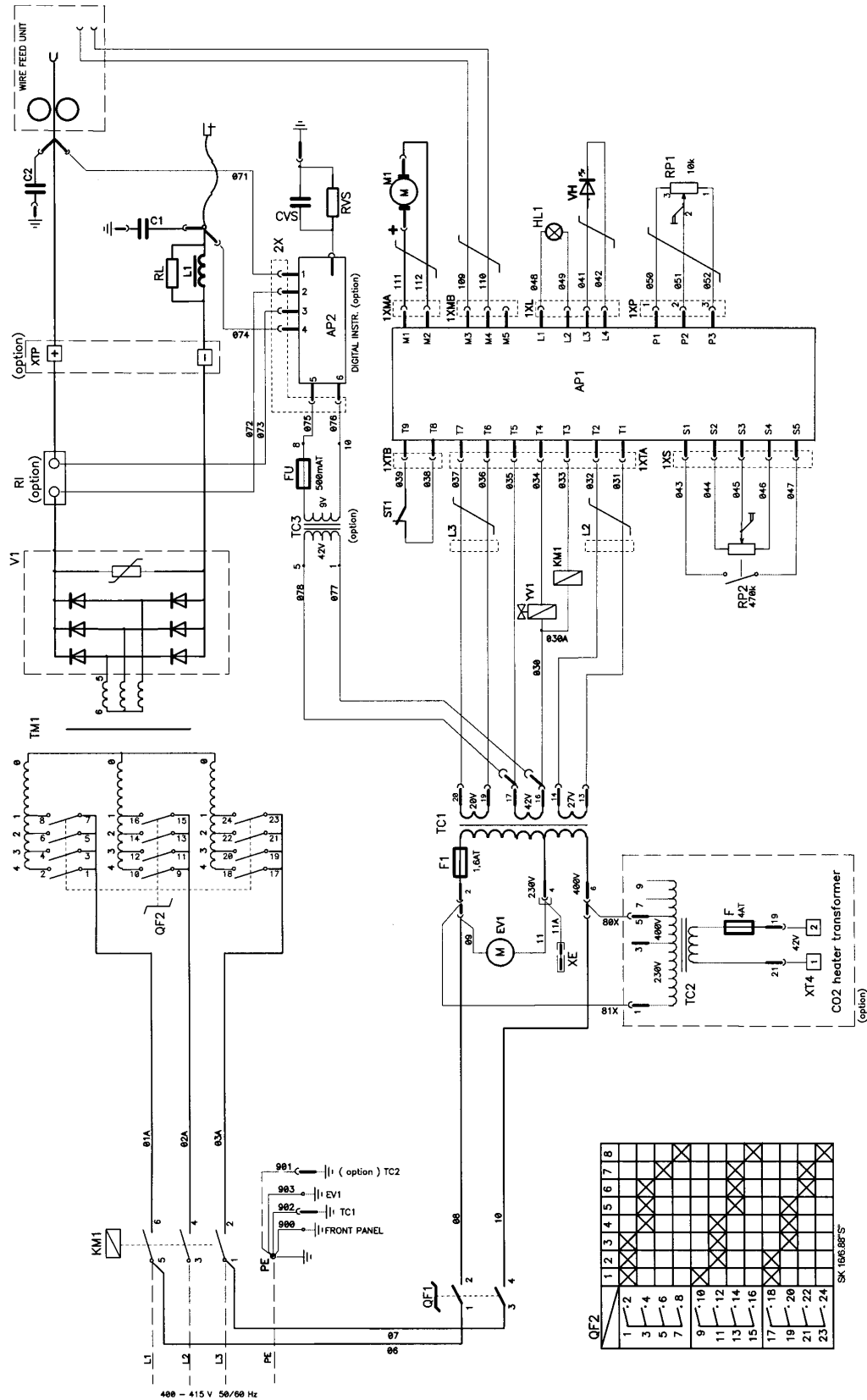

Mig C200 3ph, 400-415V

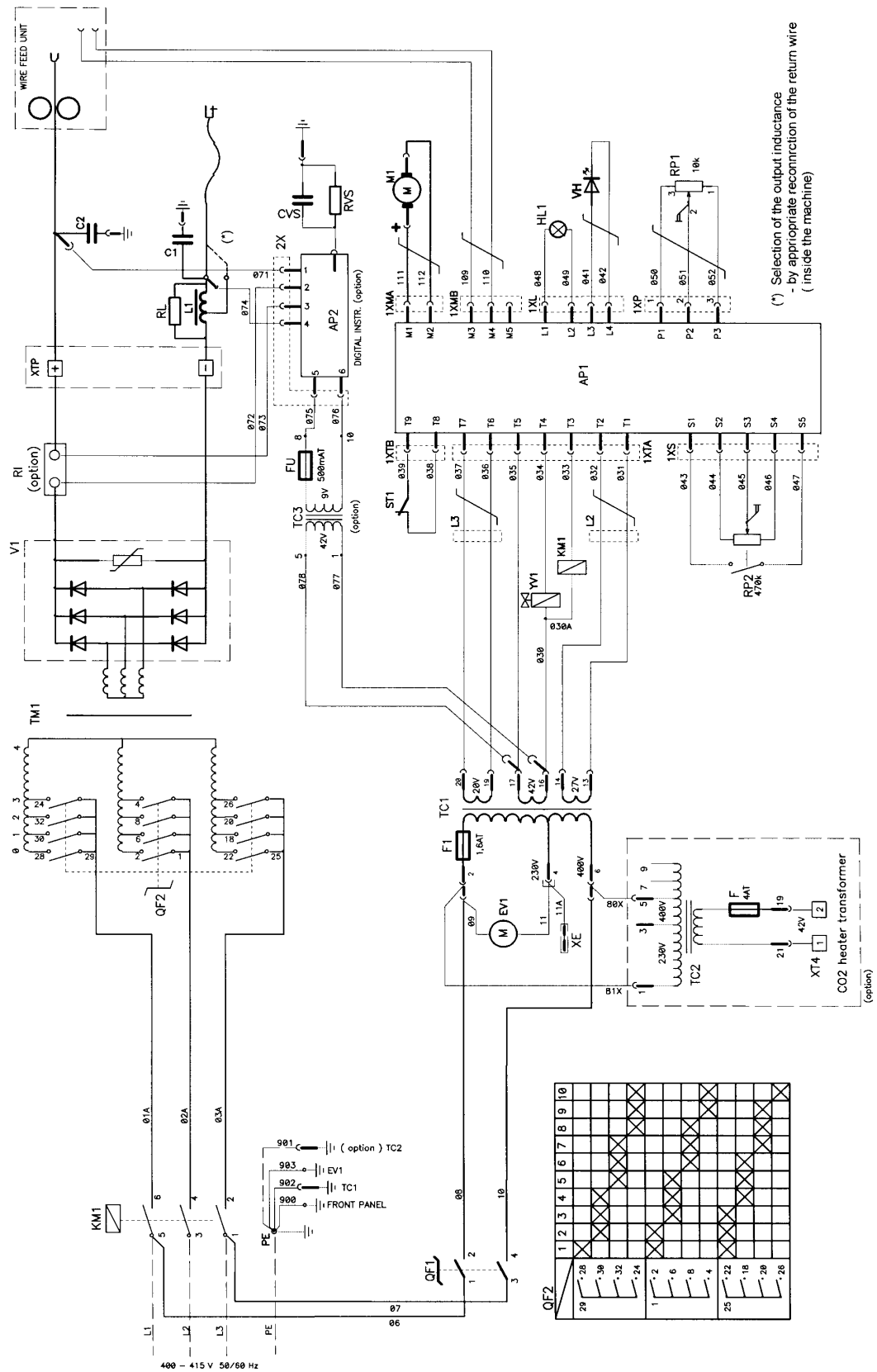

Mig C250 3ph, 400-415V

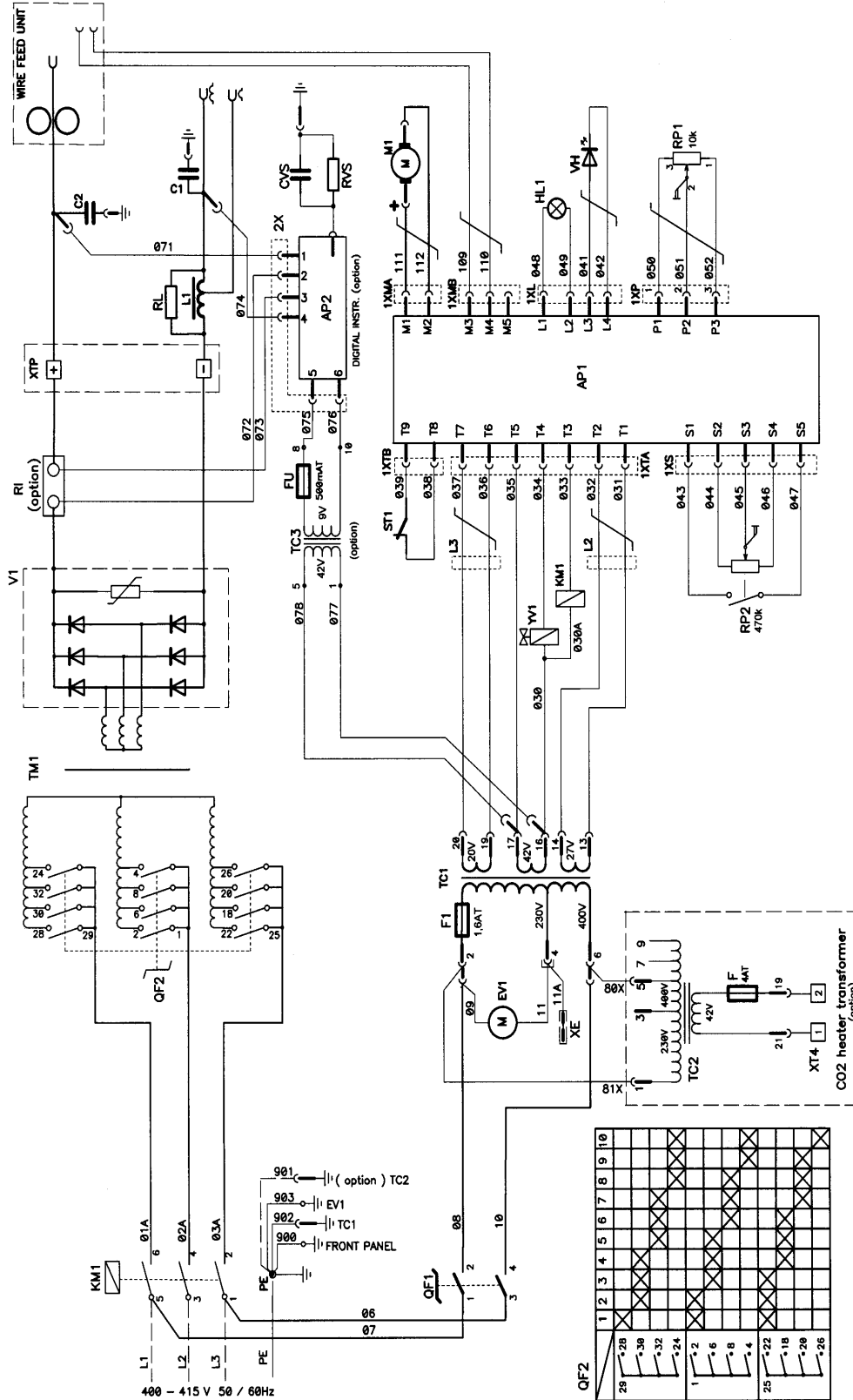

Mig C250 3ph, 230/400-415V

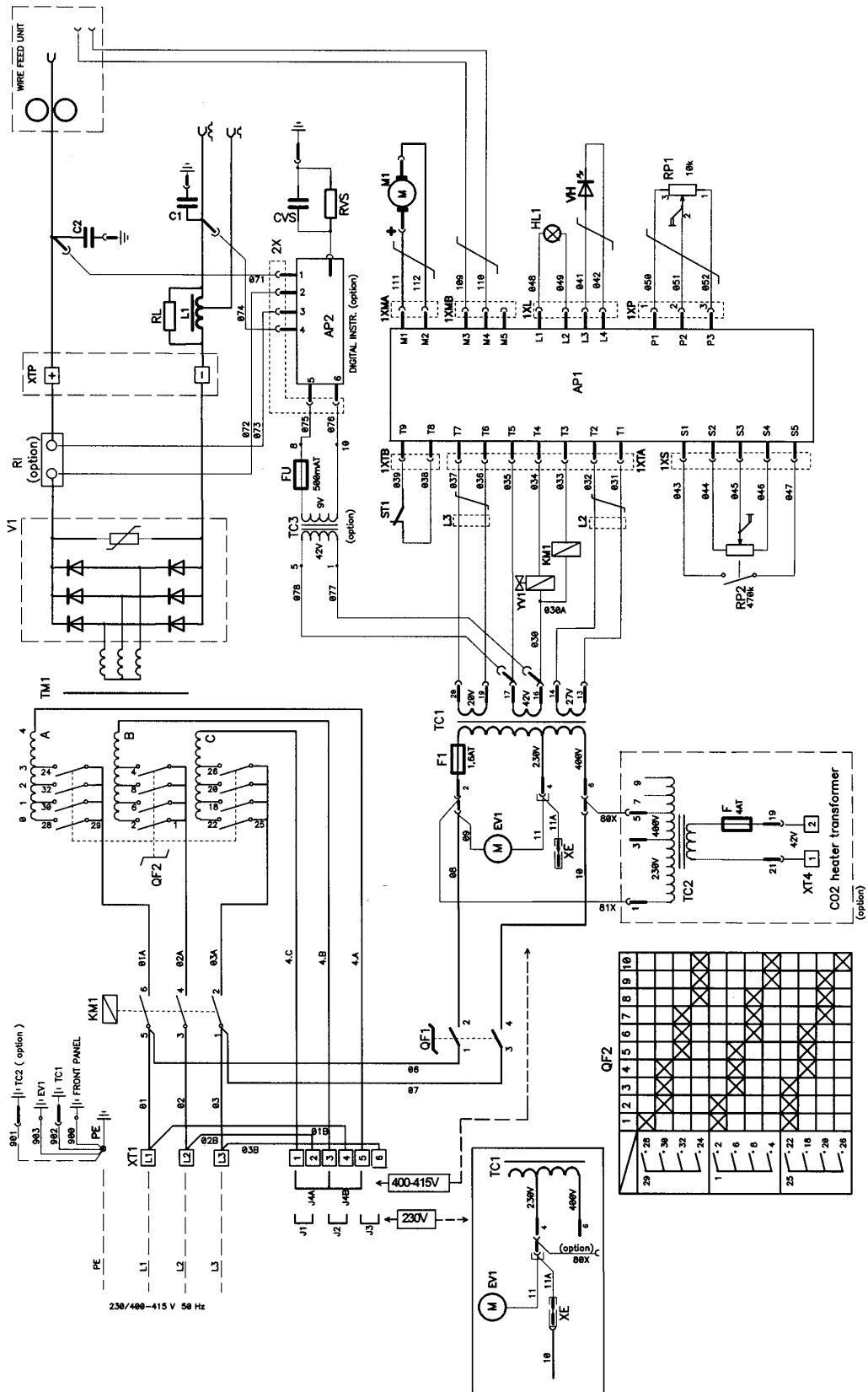

Mig C170 3ph, Mig C200 3ph, Mig C250 3ph

Order number

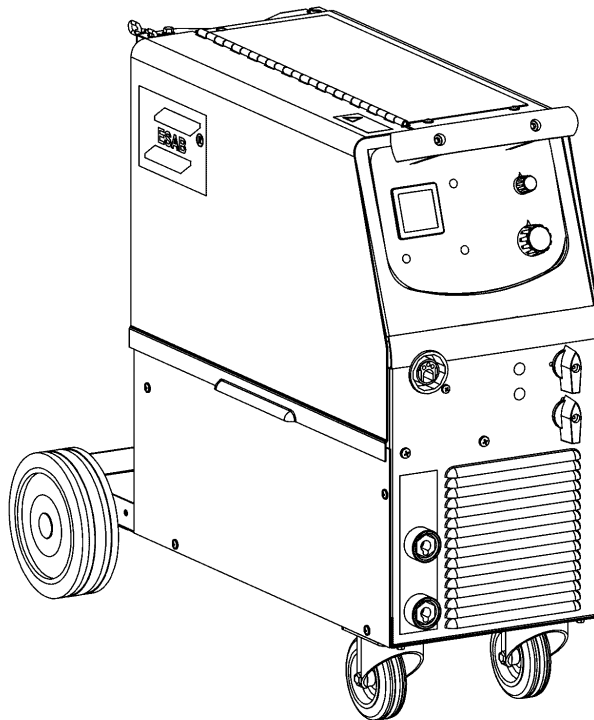

Ordering no.	Denomination	Type	Notes
0349 308 670	Power source	OrigoTM Mig C170 3ph	400-415V 3~50/60Hz
0349 308 290	Power source	OrigoTM Mig C200 3ph	400-415V 3~50/60Hz
0349 307 840	Power source	OrigoTM Mig C250 3ph	400-415V 3~50/60Hz
0349 309 090	Power source	OrigoTM Mig C250 3ph	230/400-415V 3~50/60Hz
0349 300 524	Spare parts list	Mig C170 3ph, Mig C200 3ph, Mig C250 3ph	

Technical documentation is available on the Internet at www.esab.com

Wear parts

(W. F. Mechanism 0455 890 890)

Item	Denomination	Ordering no.	Notes
A	Pressure roller	0455 907 001	
B	Feed roller	0367 556 001	Ø 0.6-0.8mm Fe, Ss, cored wire.
		0367 556 002	Ø 0.8-1.0mm Fe, Ss, cored wire.
		0367 556 003	Ø 1.0-1.2mm Fe, Ss, cored wire.
		0367 556 004	Ø 1.0-1.2mm Al wire.
C	Inlet nozzle	0466 074 001	
D	Insert tube	0455 894 001	Plastic, must be used together with item 0455 885 001, for welding with Al wire.
		0455 889 001	Steel, must be used together with item 0455 886 001.
E	Outlet nozzle	0455 885 001	Must be used together with item 0455 894 001, for welding with Al wire.
		0455 886 001	Must be used together with item 0455 889 001.

The rollers are marked with wire dimension in mm, some are also marked with inch.

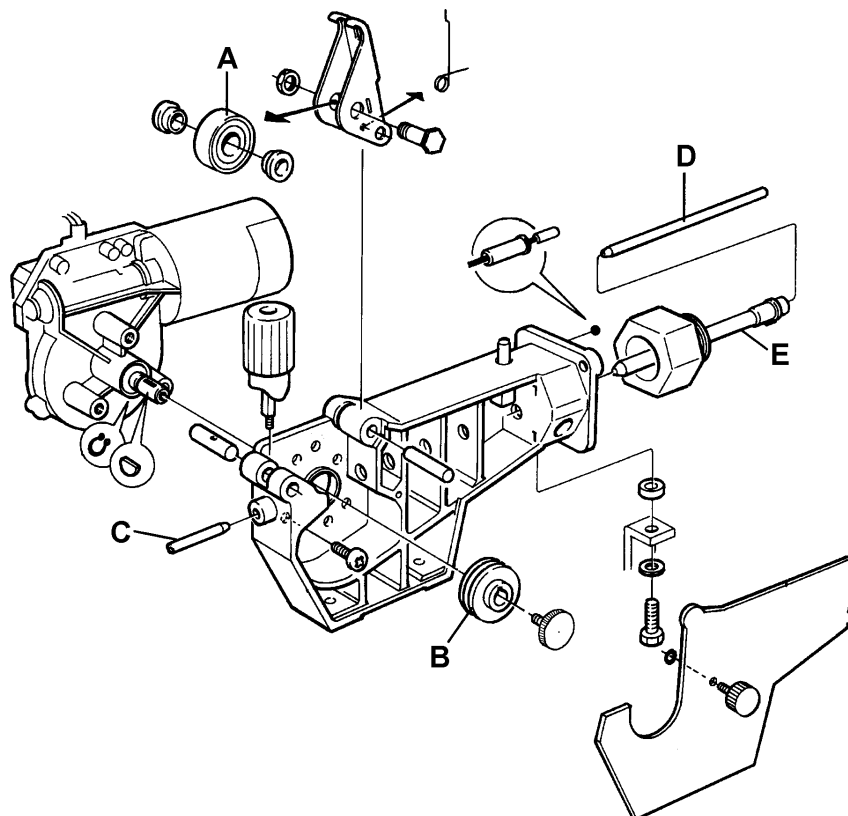







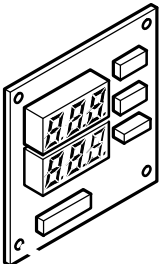
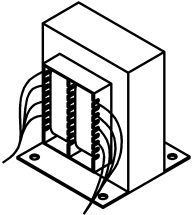
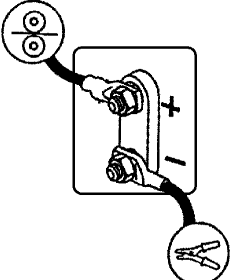

Welding with aluminium wires.

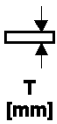
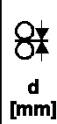
In order to weld with aluminium wires, proper rollers, nozzles and liners for aluminium wires **MUST** be used. It is recommended to use 3m long welding gun for aluminium wires, equipped with appropriate wear parts.

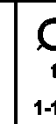
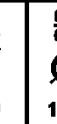
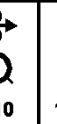

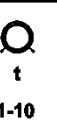

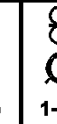
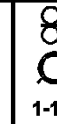
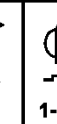
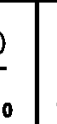

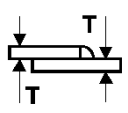
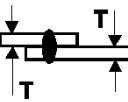



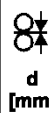



Mig C170 3ph, Mig C200 3ph, Mig C250 3ph

Accessories

	Digital meter	0349 302 598
	Transformer kit for CO₂ heater	0349 302 250
	Polarity change KIT	0349 309 310

OrigoMig C170 3ph	 T [mm]	 d [mm]	Fe Ar + 18% CO ₂			Fe CO ₂			SS Ar + 2% CO ₂		AlMg5 Ar 100%		tubular gasless wire (TUBROD OK.14.16) REVERSE POLARITY					
																		
			1-10	1-10	1-10	1-10	1-10	1-10	1-10	1-10	1-10	1-10	1-10	1-10	1-10			
	0,6	0,6	3,1	2		2,8	3		3	2						2,5	1	
		0,8	2,5	2		3	3		2,5	2								
	0,8	0,6	3,6	3		4	4		4	3							3	2
		0,8	3	3		3	4		3	3								
	1,0	0,6	5	4		5	5		5,5	4								
		0,8	3,5	4		3,5	5		4	4							3,5	3
		1,0									4	1						
	1,5	0,6	5,5	5		5,5	6		8	5								
		0,8	4,5	5		4	6		6	5							4,5	4
		1,0									5,5	2						
	2,0	0,6	6,5	6		7	7		10	6								
		0,8	5,5	6		4,5	7		8	6							6	5
1,0										6	3							
2,5	0,6	8,5	7		8,5	8		10	8									
	0,8	7	7		5,5	8		8,5	7							8	6	
	1,0									7,5	4							
3,0	0,8	8	8		6	8		7	8							10	7	
	1,0									8,5	6							
	0,6	0,6	3,6	3	7	5	5	6								3	2	7
		0,8	3	3	6	3,5	5	6										
	0,8	0,6	6,5	6	6	7	7	7										
		0,8	4,5	5	6	4	6	7								4,5	4	8
	1,0	0,6	8,5	7	8	8,5	8	8										
		0,8	7	7	6	4,5	7	10								8	6	7
	1,5	0,6	8,5	7	10	8,5	8	10										
		0,8	8	8	9			10										

GIN:0349 309 306

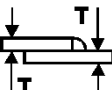
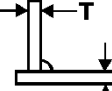
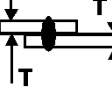
OrigoMig C200 3ph	 T [mm]	 d [mm]	Fe Ar + 18% CO ₂			Fe CO ₂			SS Ar + 2% CO ₂		AlMg5 Ar 100%		tubular gasless wire (TUBROD OK.14.16) REVERSE POLARITY							
																				
			1-10	1-10	1-10	1-10	1-10	1-10	1-10	1-10	1-10	1-10	1-10	1-10	1-10	1-10				
 	0,6	0,6	3	1		2,5	4		3	3										
		0,8	2	3		2	4						2	1						
	0,8	0,6	4	4		3	5		4	4										
		0,8	3	4		2,5	5		3	3			2,5	2						
		1,0	2	4		2	5		2,5	3			2	2						
	1,0	0,6	5	5		4,5	6		5,5	5										
		0,8	4	5		3	6		3,5	4			2,6	3						
		1,0	3	5		2,5	6		3	4	4	1	2	3						
	1,5	0,6	5,5	6		5	7		7,5	6										
		0,8	4,5	6		3,5	7		4,5	5			3	4						
		1,0	3	6		3	7		3	5	4,5	2	2,5	5						
	2,0	0,6	7	7		7,5	8		10	7										
		0,8	5,5	7		4	8		5,5	6			3,2	5						
		1,0	3,5	7		3,5	8		4	6	5	3	3,5	6						
	2,5	0,6	9	8		9,5	9		10	10										
		0,8	6,5	8		5	9		6	7			4	7						
		1,0	4	8		4	9		4,5	7	6,5	5	4,5	7						
	3,0	0,8	7	9		6	10		7,5	8			5	8						
		1,0	5	9		5	10		5,5	8	6	8	5,5	9						
	4,0	0,8	8	10		6,5	10		6	10			6	10						
1,0		5,5	10		5,5	10		5	10	7	9	7,5	10							
	0,6	0,6	5	5	6	3	5	8												
		0,8	4	5	6	2,5	5	7					3	4	7					
		1,0	3	5	5	2	5	7					3,5	4	7					
	0,8	0,6	5,5	6	8	5	7	8												
		0,8	4,5	6	6	4	7	7					3	5	8					
		1,0	3	6	6	2,5	6	8					3,5	6	8					
	1,0	0,6	7	7	8	9,5	9	8												
		0,8	5,5	7	6	4	8	8					5	8	10					
		1,0	3,5	7	6	3	7	8					5,5	9	6					
	1,5	0,8	7	9	7	6	10	9												
		1,0	5	9	5	5,5	10	7					7,5	10	7					

GIN:0349 309 307

OrigoMig C250 3ph		d [mm]	Fe Ar + 18% CO ₂				Fe CO ₂				SS Ar + 2% CO ₂			AlMg5 Ar 100%			tubular gasless wire (TUBROD OK.14.16) REVERSE POLARITY			
													High (H)			High (H)				
			1-10	1-10	L	1-10	1-10	1-10	L	1-10	1-10	1-10	Low (L)	1-10	1-10	Low (L)	1-10	1-10	L	1-10
	0,6	0,6	3	2	L	3	4	H	5	4	L									
		0,8	2,5	2	L	2,5	3	L	4	4	L					3	1	L		
	0,8	0,6	4,5	3	L	4	5	H	6	5	L									
		0,8	3	3	H	3	4	L	5	5	L					3,5	2	L		
		1,0	3,5	3	L	3,5	5	L	3,5	4	L					2	2	L		
	1,0	0,6	4,5	4	H	5	6	H	7,5	6	H									
		0,8	3,5	4	H	3	5	H	6,5	6	H					3,5	3	L		
		1,0	4,5	4	L	4	6	L	4	4	L	4,5	2	H	2,5	3	L			
	1,5	1,2	2	4	H	2,5	6	L	3	4	L	4	2	H	2	3	L			
		0,6	6	5	H	5,5	7	H	10	7	H									
		0,8	4,5	5	H	3,5	6	H	7,5	7	L					4,5	4	L		
	2,0	1,0	4	5	H	4,5	7	L	5	5	L	5	3	H	2,5	4	L			
		1,2	3	5	H	3	7	H	4	5	L	5	3	H	2	4	L			
		0,6	7,5	6	H	10	8	H												
	3,0	0,8	5,5	6	H	4	7	H	8	8	L					6,5	5	L		
		1,0	4,5	6	H	4,5	8	H	5,5	6	H	6,5	4	H	3	5	L			
		1,2	3,5	6	H	3,2	7	H	5	6	L	5,5	4	H	2,5	5	L			
	4,0	0,8	8	7	H	5,5	8	H	10	9	L					8	6	L		
		1,0	5	7	H	6,5	9	H	6,5	7	H	7	5	H	3,5	6	L			
		1,2	4	7	H	3,5	8	H	5,5	7	L	6	5	H	3	6	L			
	5,0	0,8	8,5	8	H	6,5	9	H								9,5	7	L		
		1,0	6,5	8	H	8	10	H	5,5	8	L	7	7	L	5	8	L			
		1,2	5	8	H	4	9	H	5	8	L	6	7	L	4	8	L			
	6,0	0,8	6,5	9	L	9	10	H								10	8	L		
1,0		7,5	9	H	8,5	10	H	7	9	L	8,5	8	L	7,5	9	L				
1,2		5,5	9	H	6	9	L	5,5	9	L	7	8	L	5	9	L				
	0,6	0,8	8	10	L															
		1,0	6,5	10	L	8	10	L	8,5	10	L	10	9	L	10	10	L			
		1,2	5,5	10	L	6,5	10	L	6,5	10	L	8,5	9	L	8	10	L			
	0,8	0,6	6	5	H	7	5	6	H	7										
		0,8	3,5	4	H	6	4	5	H	6						4	4	L	6	
		1,0	3	3	H	6	3	4	H	6						2,5	3	L	7	
	1,0	1,2	2,5	4	H	5	2,5	6	L	5						2	4	L	6	
		0,6	6,5	6	H	7	5,5	7	H	9										
		0,8	4,5	5	H	6	4	6	H	7						7	6	L	6	
	1,5	1,0	4	5	H	6	3,5	5	H	6						3	4	L	8	
		1,2	3,5	5	H	5	3	7	H	5						2,5	5	L	6	
		0,6	8,5	8	H	7	9,5	8	H	8										
1,5	0,8	7	7	H	6	5,5	8	H	8						9,5	8	L	6		
	1,0	4,5	6	H	6	4,5	7	H	6						4,5	6	L	8		
	1,2	3,5	6	H	5	4	8	H	5						3	6	L	7		
GIN:0349 308 428	1,5	0,8	10	9	H	7	10	10	H	7										
		1,0	6	8	H	6	6,5	9	H	6						8	8	L	8	
		1,2	4	7	H	6	5,5	9	L	5						5	9	L	7	

ESAB subsidiaries and representative offices

Europe

AUSTRIA

ESAB Ges.m.b.H
Vienna-Liesing
Tel: +43 1 888 25 11
Fax: +43 1 888 25 11 85

BELGIUM

S.A. ESAB N.V.
Brussels
Tel: +32 2 745 11 00
Fax: +32 2 745 11 28

BULGARIA

ESAB Kft Representative Office
Sofia
Tel/Fax: +359 2 974 42 88

THE CZECH REPUBLIC

ESAB VAMBERK s.r.o.
Vamberk
Tel: +420 2 819 40 885
Fax: +420 2 819 40 120

DENMARK

Aktieselskabet ESAB
Herlev
Tel: +45 36 30 01 11
Fax: +45 36 30 40 03

FINLAND

ESAB Oy
Helsinki
Tel: +358 9 547 761
Fax: +358 9 547 77 71

FRANCE

ESAB France S.A.
Cergy Pontoise
Tel: +33 1 30 75 55 00
Fax: +33 1 30 75 55 24

GERMANY

ESAB GmbH
Solingen
Tel: +49 212 298 0
Fax: +49 212 298 218

GREAT BRITAIN

ESAB Group (UK) Ltd
Waltham Cross
Tel: +44 1992 76 85 15
Fax: +44 1992 71 58 03

ESAB Automation Ltd

Andover
Tel: +44 1264 33 22 33
Fax: +44 1264 33 20 74

HUNGARY

ESAB Kft
Budapest
Tel: +36 1 20 44 182
Fax: +36 1 20 44 186

ITALY

ESAB Saldatura S.p.A.
Bareggio (Mi)
Tel: +39 02 97 96 8.1
Fax: +39 02 97 96 87 01

THE NETHERLANDS

ESAB Nederland B.V.
Amersfoort
Tel: +31 33 422 35 55
Fax: +31 33 422 35 44

NORWAY

AS ESAB
Larvik
Tel: +47 33 12 10 00
Fax: +47 33 11 52 03

POLAND

ESAB Sp.zo.o.
Katowice
Tel: +48 32 351 11 00
Fax: +48 32 351 11 20

PORTUGAL

ESAB Lda
Lisbon
Tel: +351 8 310 960
Fax: +351 1 859 1277

ROMANIA

ESAB Romania Trading SRL
Bucharest
Tel: +40 316 900 600
Fax: +40 316 900 601

RUSSIA

LLC ESAB
Moscow
Tel: +7 (495) 663 20 08
Fax: +7 (495) 663 20 09

SLOVAKIA

ESAB Slovakia s.r.o.
Bratislava
Tel: +421 7 44 88 24 26
Fax: +421 7 44 88 87 41

SPAIN

ESAB Ibérica S.A.
Alcalá de Henares (MADRID)
Tel: +34 91 878 3600
Fax: +34 91 802 3461

SWEDEN

ESAB Sverige AB
Gothenburg
Tel: +46 31 50 95 00
Fax: +46 31 50 92 22

ESAB international AB

Gothenburg
Tel: +46 31 50 90 00
Fax: +46 31 50 93 60

SWITZERLAND

ESAB AG
Dietikon
Tel: +41 1 741 25 25
Fax: +41 1 740 30 55

UKRAINE

ESAB Ukraine LLC
Kiev
Tel: +38 (044) 501 23 24
Fax: +38 (044) 575 21 88

North and South America

ARGENTINA

CONARCO
Buenos Aires
Tel: +54 11 4 753 4039
Fax: +54 11 4 753 6313

BRAZIL

ESAB S.A.
Contagem-MG
Tel: +55 31 2191 4333
Fax: +55 31 2191 4440

CANADA

ESAB Group Canada Inc.
Mississauga, Ontario
Tel: +1 905 670 02 20
Fax: +1 905 670 48 79

MEXICO

ESAB Mexico S.A.
Monterrey
Tel: +52 8 350 5959
Fax: +52 8 350 7554

USA

ESAB Welding & Cutting Products
Florence, SC
Tel: +1 843 669 44 11
Fax: +1 843 664 57 48

Asia/Pacific

AUSTRALIA

ESAB South Pacific
Archerfield BC QLD 4108
Tel: +61 1300 372 228
Fax: +61 7 3711 2328

CHINA

Shanghai ESAB A/P
Shanghai
Tel: +86 21 2326 3000
Fax: +86 21 6566 6622

INDIA

ESAB India Ltd
Calcutta
Tel: +91 33 478 45 17
Fax: +91 33 468 18 80

INDONESIA

P.T. ESABindo Pratama
Jakarta
Tel: +62 21 460 0188
Fax: +62 21 461 2929

JAPAN

ESAB Japan
Tokyo
Tel: +81 45 670 7073
Fax: +81 45 670 7001

MALAYSIA

ESAB (Malaysia) Snd Bhd
USJ
Tel: +603 8023 7835
Fax: +603 8023 0225

SINGAPORE

ESAB Asia/Pacific Pte Ltd
Singapore
Tel: +65 6861 43 22
Fax: +65 6861 31 95

SOUTH KOREA

ESAB SeAH Corporation
Kyungnam
Tel: +82 55 269 8170
Fax: +82 55 289 8864

UNITED ARAB EMIRATES

ESAB Middle East FZE
Dubai
Tel: +971 4 887 21 11
Fax: +971 4 887 22 63

Africa

EGYPT

ESAB Egypt
Dokki-Cairo
Tel: +20 2 390 96 69
Fax: +20 2 393 32 13

SOUTH AFRICA

ESAB Africa Welding & Cutting Ltd
Durbanvill 7570 - Cape Town
Tel: +27 (0)21 975 8924

Distributors

For addresses and phone numbers to our distributors in other countries, please visit our home page

www.esab.com



www.esab.com

