

INVERTEC 175TP

Spare Parts.....	1
Figure A: Casing	1
Figure B: Internal	2
Figure C: External	3
Electrical Schematic.....	4



Spare Parts

SP50394 REV01
02/19

ASSEMBLY PAGE NAME			Casing	Internal	External			
CODE NO.:	K NO.:	FIGURE NO.:	A	B	C			
50394	K14169-1	INVERTEC 175TP	1	1	1			

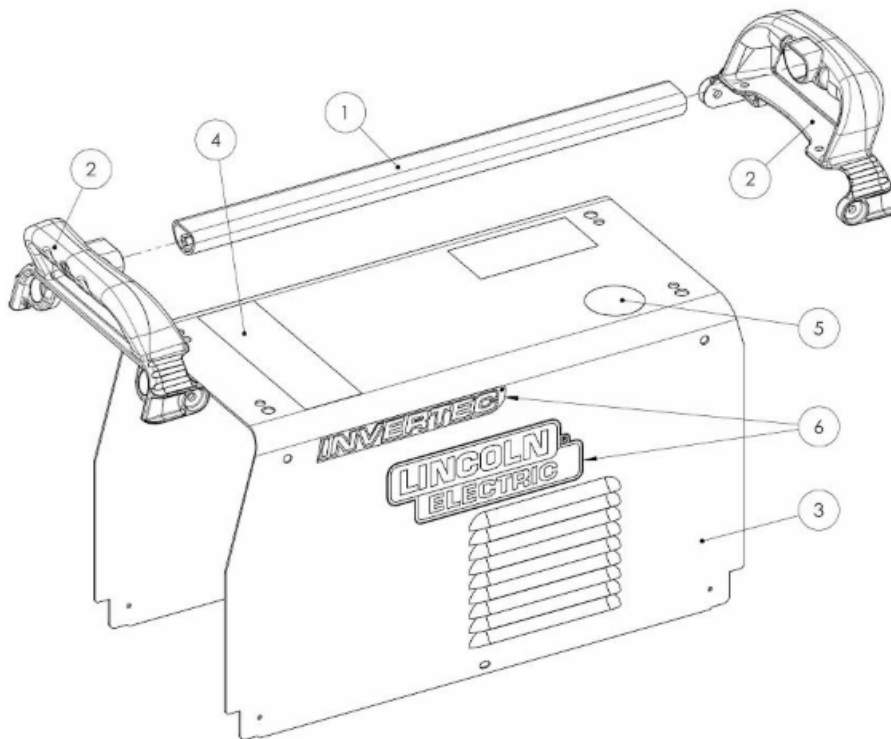

Figure A

Figure A. Invertec 175TP Casing

Item	Description	Part Number	Qty	1	2	3	4	5	6	7
1	HANDLE L=418MM	W92X0228-8R	1	X						
2	HANDLE CASE	W95X1387R	2	X						
3	WRAPAROUND	R-3019-484-1R	1	X						
4	STICKER D-2837-728-1	2719-107-728R	1	X						
5	STICKER D-2837-731-2	2719-107-823R	1	X						
6	NAMEPLATE INVERTEC+LOGO 270SX	W07X1186R	2	X						

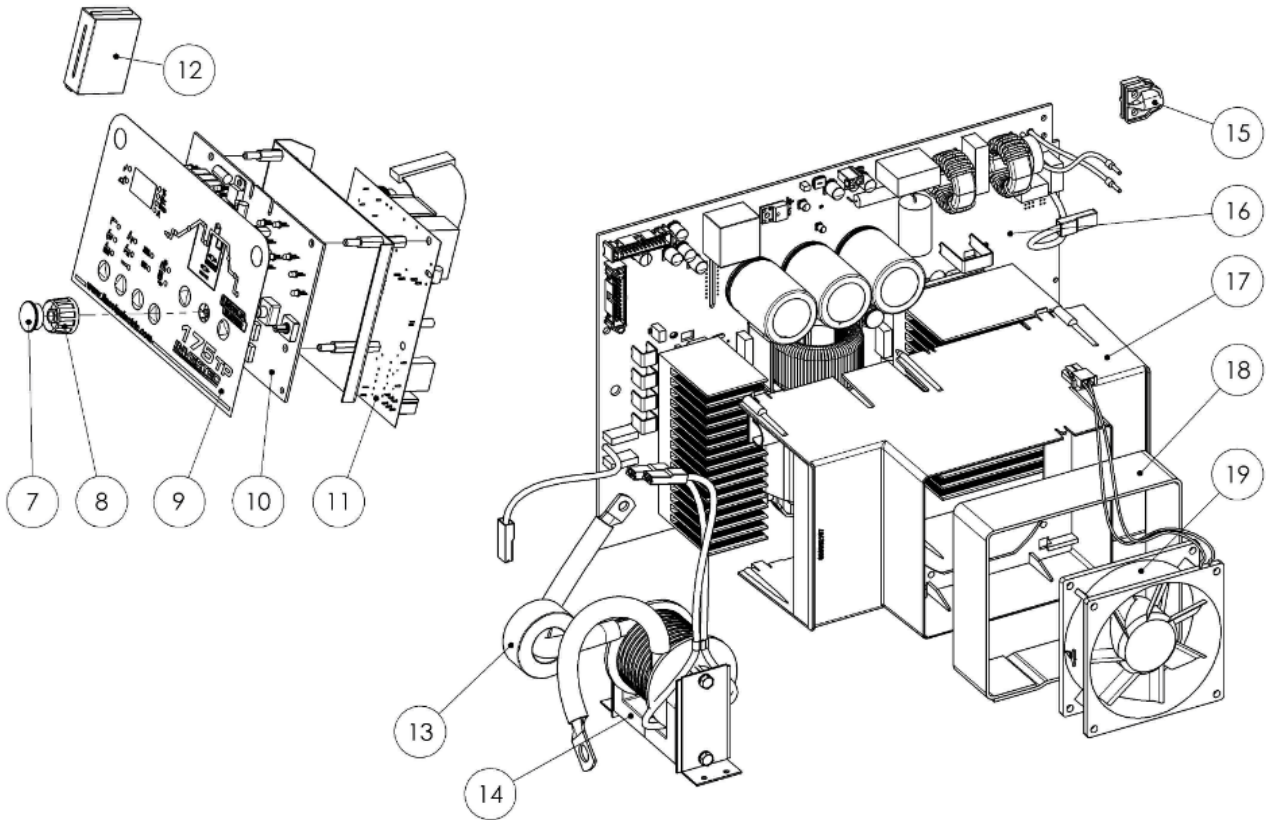

Figure B

Figure B. Invertec 175TP Internal

Item	Description	Part Number	Qty	1	2	3	4	5	6	7
7	HOOD	W000352077	1	X						
8	KNOB	W000352038	1	X						
9	FRONT NAMEPLATE	R-0010-720-1R	1	X						
10	PCB CONTROL PANEL 180A	W000376582	1	X						
11	PCB INTERFACE	W000274816	1	X						
12	FERRITE FLAT	W000376585	1	X						
13	FERRITE TOROID	W000376584	1	X						
14	COUPLER (SELF)	W000070016	1	X						
15	BLOCK FIXING	W000352073	3	X						
16	PCB POWER	W000376581	1	X						
17	AIR CONVEYOR 92X92	W000270555	1	X						
18	ADHESIVE EXTENSION PVC	800035769R	1	X						
19	ELECTRIC FAN	W000376266	1	X						

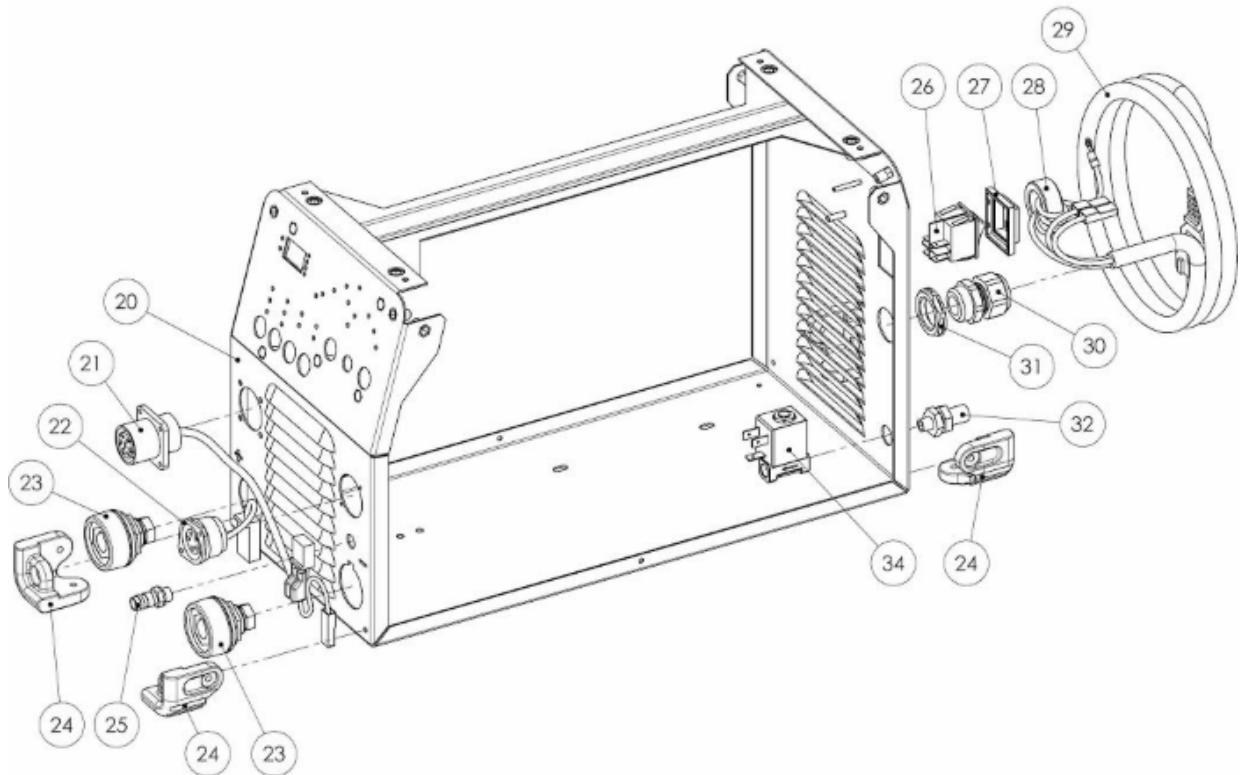

Figure C

Figure C. Invertec 175TP External

Item	Description	Part Number	Qty	1	2	3	4	5	6	7
20	MAIN FRAME	R-3019-482-1R	1	X						
21	REMOTE CABLING	R-5241-058-1R	1	X						
22	C5B	R-5241-057-1R	1	X						
23	QUICK SOCKET FOR PANEL	W7690350R	2	X						
24	KIT 4 ANTI-SLIP FEET	W95X1149R	4	X						
25	RACCORD RAPIDE GAZ	W8800082R	1	X						
26	SWITCH	W000352016	1	X						
27	WATERPROOF CAP	1115-299-225R	1	X						
28	TOROIDE 3C90 TN32-19-13	033505006R	1	X						
29	INPUT CABLE 3X2,5MM2 3.3M	W000274825	1	X						
30	CABLE CLAMP	W000227612	1	X						
31	KNOB CABLE CLAMP	W000352033	1	X						
32	RACCORD D'ENTREE 1/4-1/8	W8896074R	1	X						
34	SOLENOID VALVE	W000227800	1	X						

Electrical Schematic

