

The perfect pipe handling solution for heavy wall fabrication projects.

Key Plant Adjust-O-Stands are a great extension on the light duty pipe stands and can carry a much larger load than most other product's available on the market. Adjust-O-Stands safely hold big pipe diameters and are full height adjustable.

**Heavy-duty solid acme leadscrew for durable, yet precise adjustment under load.**

### Adjust-O-Stand ST2

Specification	Model: DRIVE - KP-AOS-ST2D	Model: IDLER - KP-AOS-ST2I
Load Capacity	4000lb (1800kg)	4000lb (1800kg)
Set Capacity	4 Ton (2600kg)	4 Ton (2600kg)
Pipe Diameter Range	2" (50mm) - 36" (914mm)	2" (50mm) - 36" (914mm)
Operational Height	26" (660mm) - 40" (1015mm)	26" (660mm) - 40" (1015mm)
Power Requirement	110V, single phase, 50/60Hz	
Weight	270lb (122kg)	160lb (72.5kg)



### Options

- Stationery Self-Levelling Feet ①
- Traversing Rail Mount Bogie Wheels ②  
Wheel centre points width: 26" (670mm)
- Swivel Castor Kit with Brakes

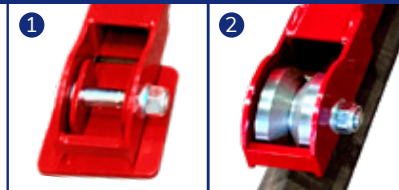

### Adjust-O-Stand ST2+ Pipe Trolley

Specification	Model: KP-AOS-ST2PT
Load Capacity	8000lb (3650kg)
Set Capacity	3.6 Ton (2600kg)
Pipe Diameter Range	2" (50mm) - 36" (914mm)
Operational Height	33" (850mm) - 41" (1050mm)
Power Requirement	110V, single phase, 50/60Hz
Foot Print	24" (610mm) x 46" (1165mm)
Total Weight	500.4lb (227kg)



Adjust-O-Stand ST2 mounted on a mobile fabricated trolley to enable the easy movement of pipes around the workshop, removing the need for manual handling and lifting devices. The idler can be moved along the length of the trolley to accommodate various lengths of the work piece.

### Adjust-O-Stand ST2 - DRIVE

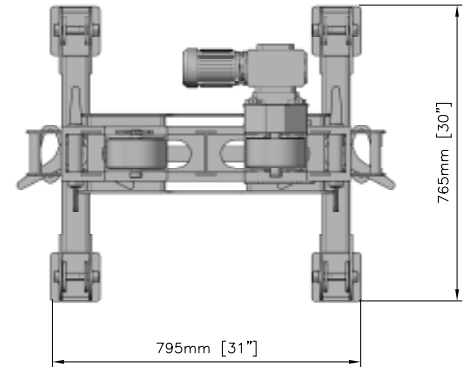
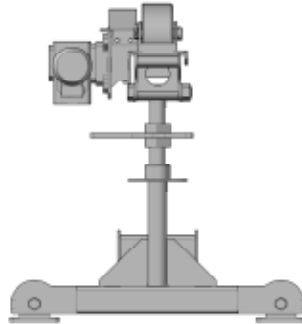
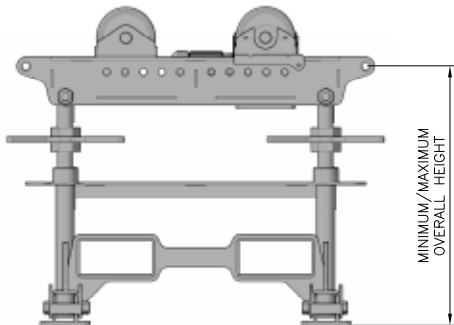

### Adjust-O-Stand ST2 - IDLER

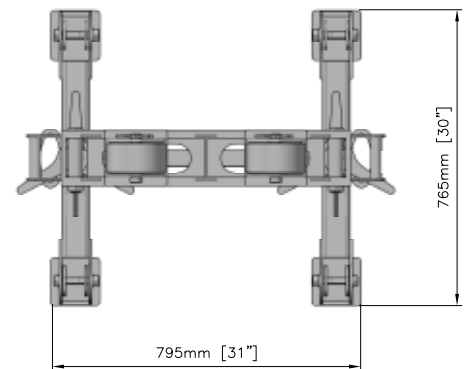
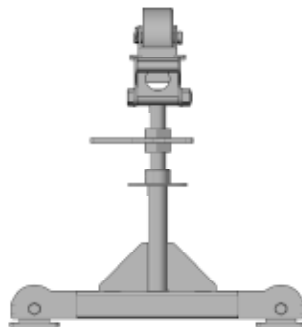
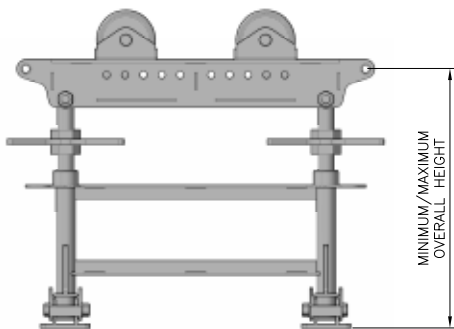

### Adjust-O-Stand ST2+ Pipe Trolley

